

PROPRIETARY INFORMATION
COMPANY CONFIDENTIAL

REV.	ECN. NO.	DESCRIPTION	ENG	DATE
A		INITIAL	Lucky	06/20/20'

SPECIFICATION:

1. CURRENT RATING:DC 0.5A MAX.
2. VOLTAGE RATING:DC 12V.
3. CONTACT RESISTANCE:50m Ω MAX.
4. INSULATION RESISTANCE:100M Ω MIN. AT 500V DC.
5. WITHSTANDING VOLTAGE:500V AC FOR 1 MINUTE.
6. LIFE TEST:5000 CYCLES MIN,
7. MATING FORCE:3~30N,
UNMATING FORCE:3~30N.
8. TEPROOF LEVEL:IPX7

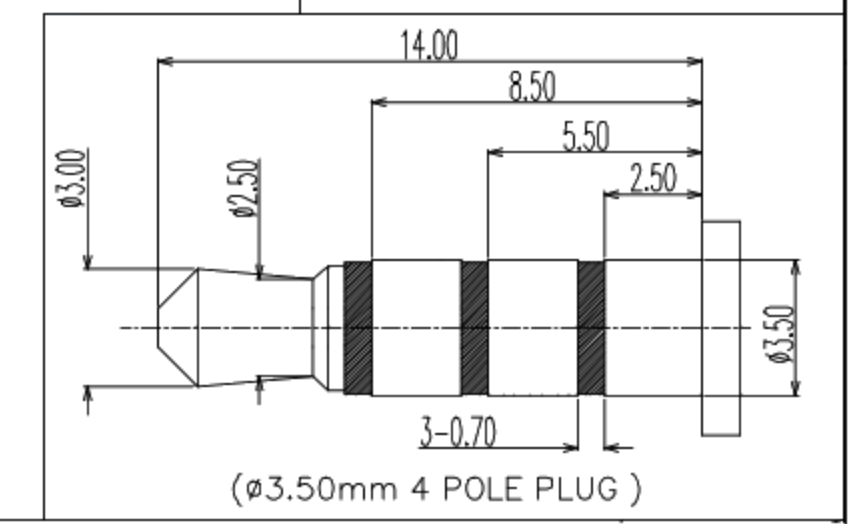
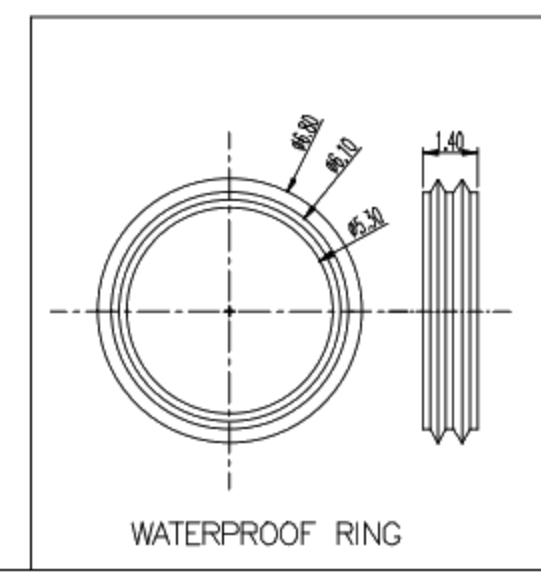
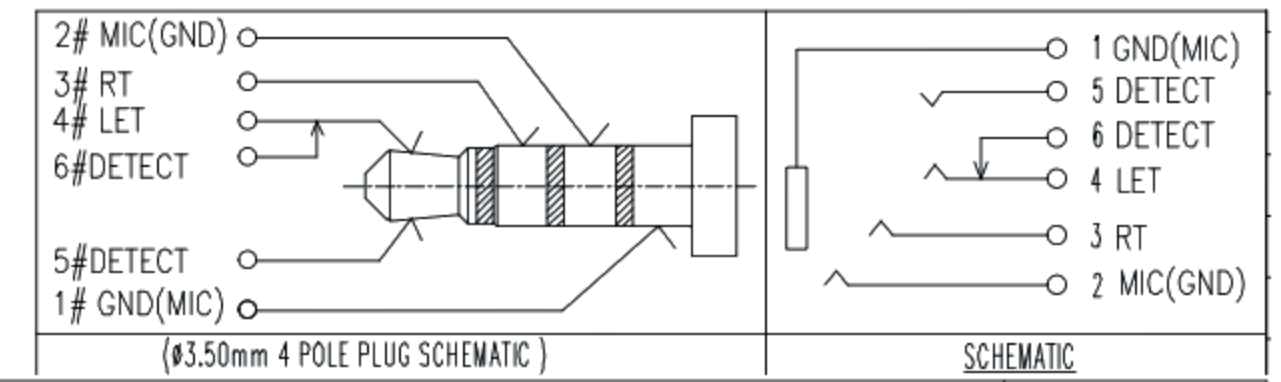
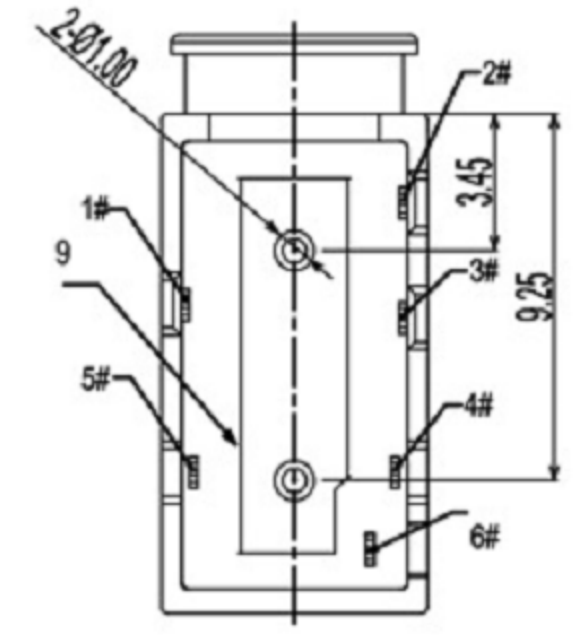
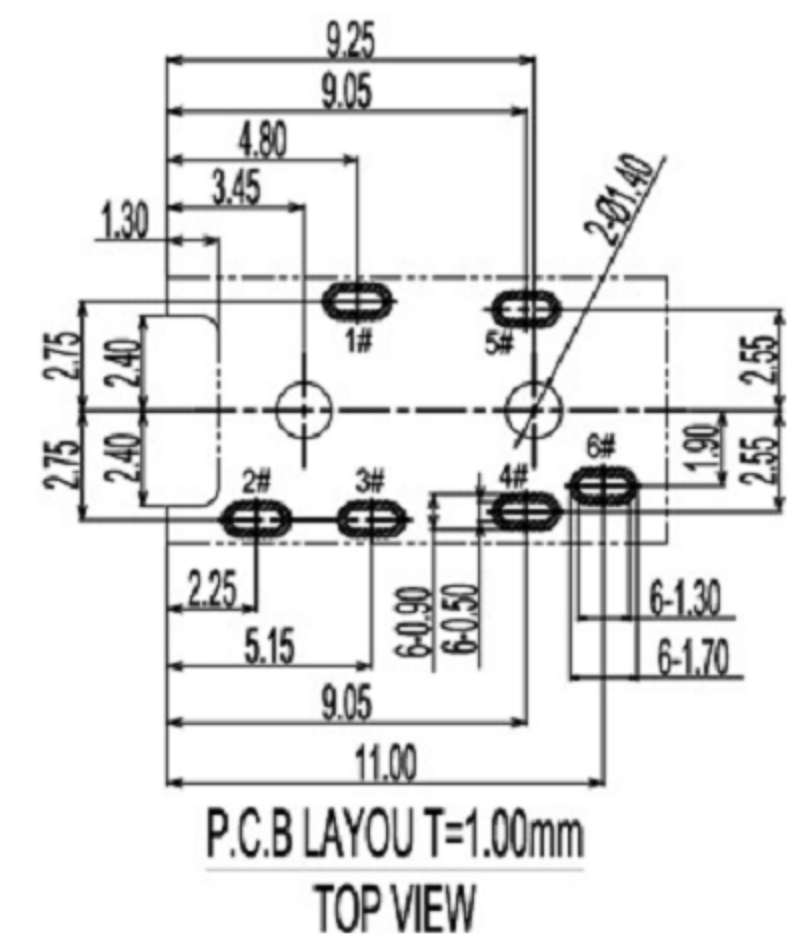
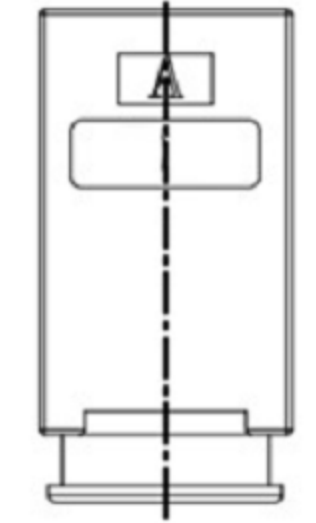
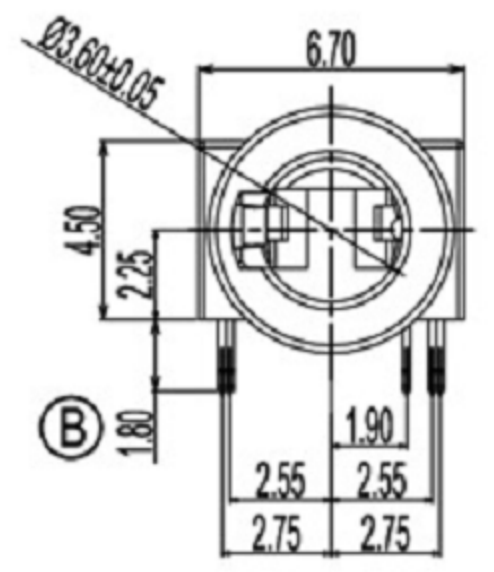
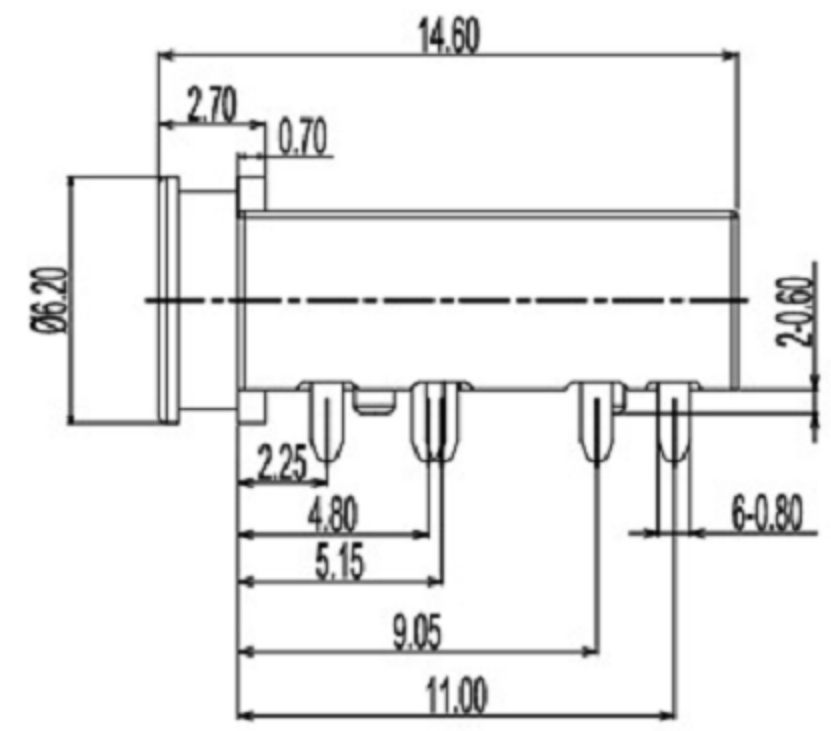
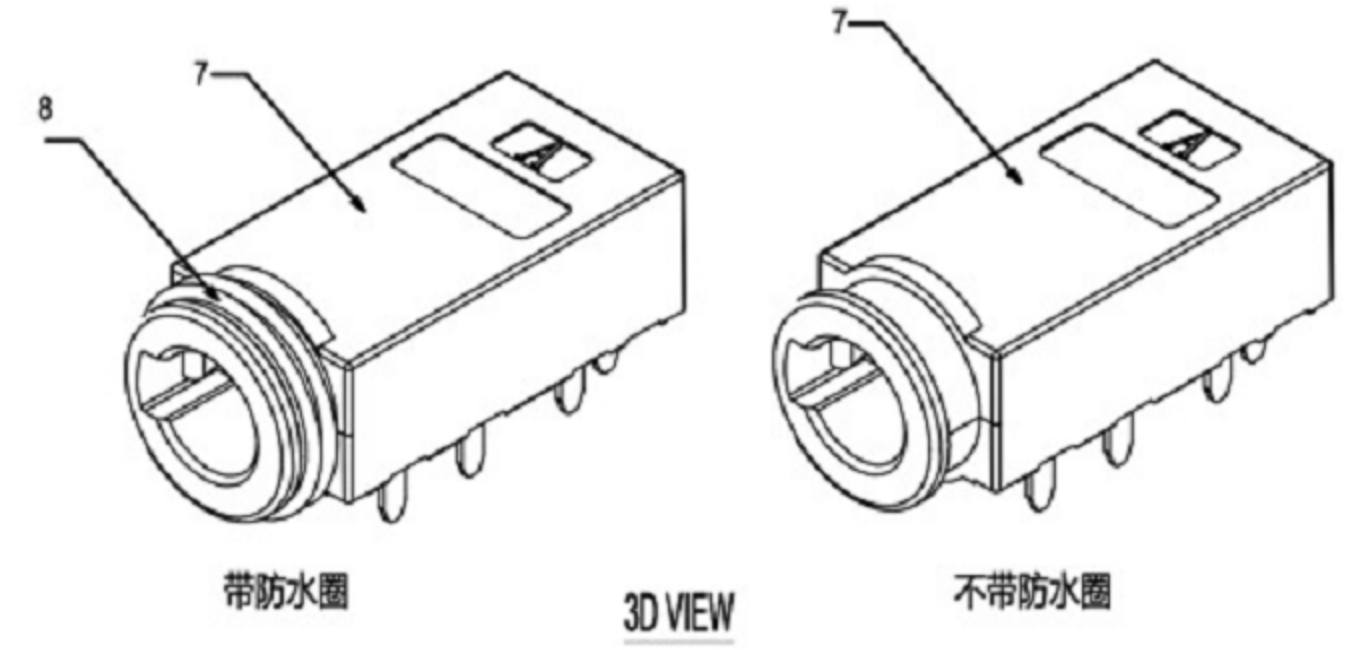

9	SILICA GEL	1	SILICA GEL COLOR BLACK	
8	COVER	1	HIGH TEMPERATURE PLASTIC COLOR BLACK	
7	HOUSING	1	HIGH TEMPERATURE PLASTIC COLOR BLACK	
6	SHELL	1	PHOSPHOR BRONZE; NICKEL PLATED OVERALL	
5	TERMINAL 5#	1	PHOSPHOR BRONZE; GOLD FLASH ON CONTACT AREA; GOLD FLASH PLATING ON SOLDER	
4	TERMINAL 4#	1		
3	TERMINAL 3#	1		
2	TERMINAL 2#	1		
1	TERMINAL 1#	1	PHOSPHOR BRONZE; GOLD FLASH ON CONTACT AREA; GOLD FLASH PLATING ON SOLDER	
ITEM	NAME	Q'TY	DESCRIPTION	NOTE

MEASURE POINT: □QP
 QUADRANT POINT □TP
 TANGENCY POINT □IP
 INTERSECTION POINT □IP

UNLESS OTHERWISE SPECIFIED, TOLERANCE:
 X. ±0.25
 X.X ±0.20
 X.XX ±0.15
 X.XXX ±0.10
 ANGULAR ±3°

东莞市高迪电子有限公司 DONGGUANSHI Gao Di ELECTRONICS TECHNOLOGY CO.,LTD.		
DESIGN:	DATE:	TITLE:
CHECKED:	DATE:	ø3.5mm PHONE JACK
APPROVED:	DATE:	
PART NO. PJT-0089	REV.: A	SCALE: 1:1
DRAWING NO.	SIZE: A4	SHEET: 1/1